



SOLID FUEL HEATER 'JAYLINE SS200 FS CA 2006' INSTALLATION & OPERATION INSTRUCTIONS

We thank you for choosing Jayline and welcome you among the many happy Jayline customers. Please keep this booklet as a reference guide.

Installation of Jayline Solid Fuel Heater

Please follow carefully all dimensions and recommendations provided on the individual specification sheet for your model of heater. These dimensions comply with the required standards of New Zealand (AS/NZS 2918:2001).

As building and safety standards vary for wood heaters please check with your local building inspector or local authority prior to installation as a permit may be required.

Jayline recommends you use a qualified solid fuel heater installer or a registered plumber to install your woodstove. Your dealer or heating specialist should be able to help with recommendations.

INSTALLATION – FREESTANDING MODELS

1. Unpack the heater and check for any transport damage.
2. Inspect the outside of the building to ascertain the point of roof penetration for the flue system. If a flue system is built and installed to the correct height it will normally prevent downdraught problems during windy weather and eliminate smoke spillage problems due to lack of draught.
3. Check suitable siting for appliance and size of floor protector. Ensure position of the flue pipe and, if possible, enter the ceiling space to check that no major structural members will be affected by the flue pipe path.
4. Check that the sub-structure is capable of carrying the heater (i.e. weight consideration on the floor).
5. Check measurements of the heater to combustibles or shield.
6. Locate the heater in the required position (also see 'Fitting Seismic Restraint' after installation instruction #14).
7. Using a plumb line, mark the flue penetration hole in the ceiling using a thin nail driver through the ceiling.
8. Cut the square ceiling hole to the required size and frame out.
9. Install the flue system (see flue installation instructions supplied with flue system). Remember:
 - The flue system should rise vertically from the appliance with as few offsets as possible. Offsets should be avoided where possible as each change in direction creates a resistance to airflow.
 - The flue system must be well sealed with a minimum of 3 fixings at each joint.
 - The flue pipe penetrating the chimney must continue to the minimum length of 4.6m from the top of the floor protector to the cowl.
 - Flue exiting more than 3 metres from the ridgeline must not terminate less than 1 metre above the roof penetration (see diagram 1 below).
 - Where the top of the flue pipe is more than 2 metres above its highest fixing point, it must be stayed against high winds.

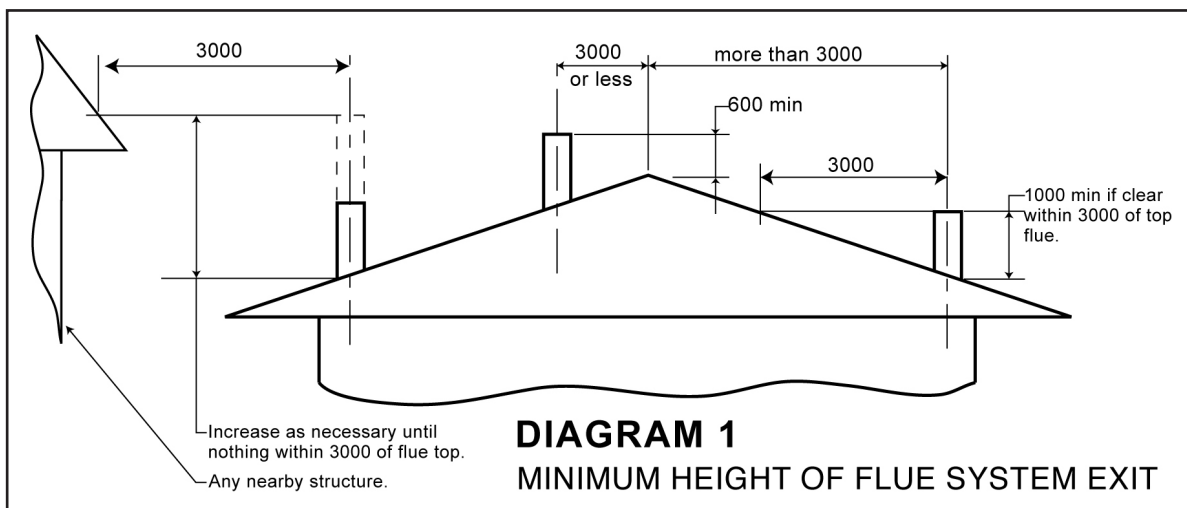

10. Drill and fix flue system into flue spigot with stainless steel self-tapping screws.
11. Drill and secure the appliance to the floor protector using the two rear holes behind the pedestal.
12. Fit steel top baffle plate into position by resting plate on rear side pins. Line up notches in baffle with forward side pins. Lift baffle above side pins and slide baffle to the back of the heater. Correct final position has the baffle rear hard against the back of firebox and the baffle's folded front edge turned downwards. (See diagram 2).

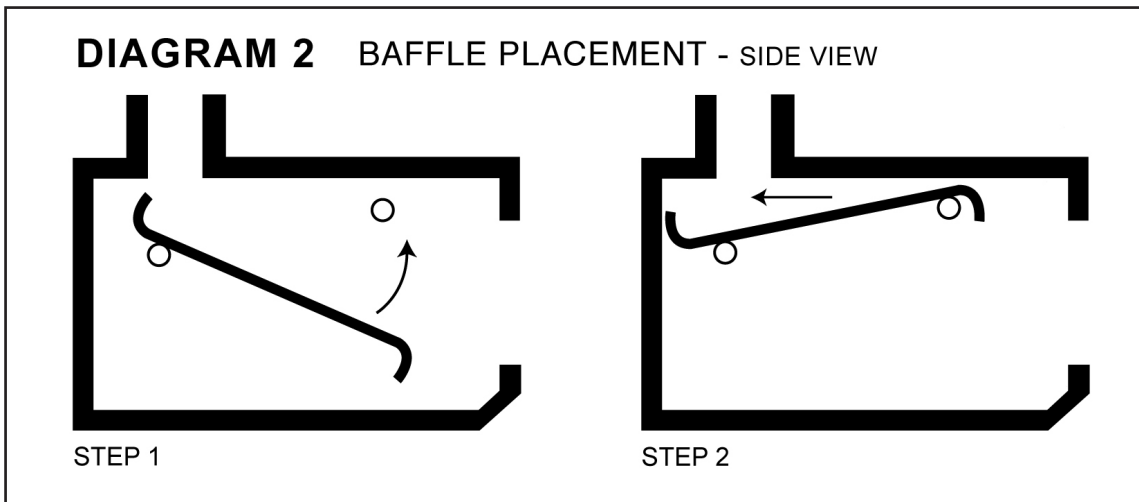

13. Position bricks in place so that they fit behind the rear mounting pin and the base mounting pin (see diagram 3 below). This is designed to be a tight fit so that the bricks are secure when in place. The angled edge of the brick should be at the front on the side of the firebox. (Bricks for clean air models are fitted behind mounting retainers that bolt onto the firebox sides. Bricks should line the sides and rear of clean air models).

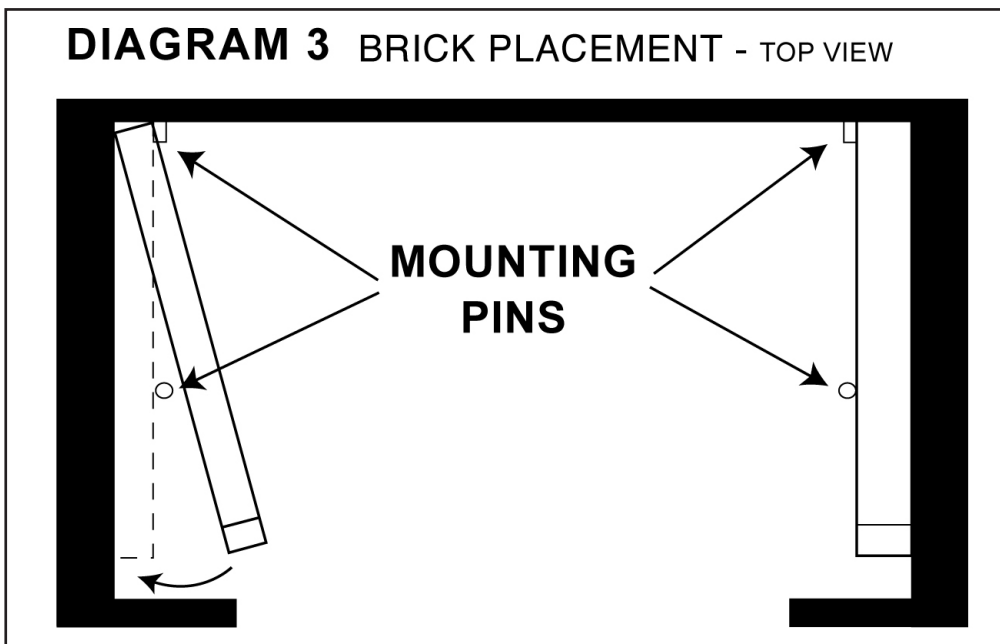

14. Check the operation of the appliance using 4 to 5 sheets of newspaper to ensure there is a good draught. Crumple up newspaper and light, wait until paper is burning fiercely, and turn off all air supply. When the firebox fills with smoke, open all air supplies. The firebox should clear of smoke immediately and the remaining paper should re-ignite. If this does not happen, it is generally found that there is either an air leak in the flue pipe system or it is too short. Check for leaks first before experimenting with flue pipe lengths.

FITTING SEISMIC RESTRAINT

The Floor Protector must be mechanically fixed to the floor by bolting or screwing.

Note: Floor Protector to be fixed by gluing when on a concrete floor that may have water pipes or electrical wires present. The appliance can then be bolted to the floor protector with two 6mm x 50mm dynabolts.

Warnings

- 1. WARNING: THE HEATER AND FLUE SYSTEM SHALL BE INSTALLED IN ACCORDANCE WITH AS/NZS 2918:2001 (INCLUDING APPENDIX E AND F) AND THE APPROPRIATE REQUIREMENTS OF THE RELEVANT BUILDING CODE OR CODES.**
- 2. WARNING: HEATERS INSTALLED IN ACCORDANCE WITH THIS STANDARD SHALL COMPLY WITH THE REQUIREMENTS OF AS/NZS 4013:1999 WHERE REQUIRED BY THE REGULATORY AUTHORITY, i.e. THE HEATER SHALL BE IDENTIFIABLE BY A COMPLIANCE PLATE WITH THE MARKING 'TESTED TO AS/NZS 4013:1999'.**
- 3. ANY MODIFICATION OF THE HEATER THAT HAS NOT BEEN APPROVED IN WRITING BY THE TESTING AUTHORITY IS CONSIDERED TO BE IN BREACH OF THE APPROVAL GRANTED FOR COMPLIANCE WITH AN/NZS 4013:1999.**
4. CAUTION: MIXING OF HEATER OR FLUE SYSTEM COMPONENTS FROM DIFFERENT SOURCES OR MODIFYING THE DIMENSIONAL SPECIFICATION OF COMPONENTS MAY RESULT IN HAZARDOUS CONDITIONS. WHERE SUCH ACTION IS CONSIDERED, THE MANUFACTURER SHOULD BE CONSULTED IN THE FIRST INSTANCE.
5. CAUTION: CRACKED AND BROKEN COMPONENTS, e.g. GLASS PANELS OR CERAMIC BRICKS MAY RENDER THE INSTALLATION UNSAFE.

Any variation from these installation instructions or any doubts about them must be checked against the requirements of the AS/NZS 2918:2001.

Correct Operation of Your Jayline Solid Fuel Heater

Simply by burning your Jayline Heater correctly, you can improve efficiency, reduce fuel consumption and minimise air pollution.

STARTING A NEW FIRE

NB: PLEASE LOAD YOUR JAYLINE CLASSIC CLEAN AIR FIRE, FROM FRONT TO REAR ONLY.

Please note: If lighting the heater for the first time dust heater, glass, trim and flue before firing to avoid particles sticking or discolouring. Once fired, some smoke and vapour will be released as the VHT painted surfaces enter the final curing process. Open all windows and doors while running the fire on high for up to 3 hours. People with respiratory, heart or other relevant medical conditions should avoid inhaling vapours during the curing process. All VHT paint will cure at the highest temperature achieved and will produce smoke again if this temperature is exceeded.

To start and maintain a good fire you will need the following ingredients:

1. A small quantity of newspaper (do not use coloured or coated paper);
2. A packet of firelighters (optional)
3. A quantity of finely split, dry soft wood kindling in a variety of sizes; and
4. Seasoned firewood split into a range of piece sizes.

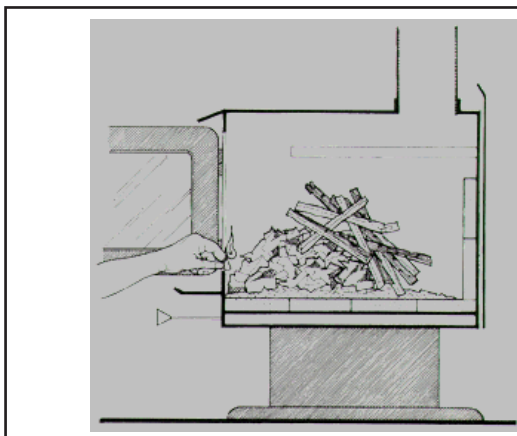

TO BUILD A QUICK, HOT FIRE

Use plenty of crumpled newspaper and dry, finely-split kindling. Set the air control fully open. Light the newspaper near where the combustion air enters the firebox. When a kindling fire is built properly, you should expect instant ignition.

The first step is to crumple half a dozen sheets of newspaper and put them just inside the firebox. The amount of newspaper you need, will depend on the firebox size and the dryness and fineness of the kindling you are using. The drier and finer the kindling, the less newspaper you need. Many people make the mistake of using too little newspaper. Be generous with the newspaper and you will have more success. Putting some firelighter halves under the newspaper can also help sustain firebox temperature until the wood is burning.

On top of the paper place 10 to 15 pieces of finely split, dry kindling. Soft woods such as cedar or pine, make good kindling. Ideally, the kindling should be placed on and behind the newspaper so that the combustion air reaches the newspaper fast where you ignite it. It is also a good idea to add two or three very small pieces of firewood to the kindling load before lighting.

Set the air control to fully open, light the firelighters or the newspaper and close but do not latch the door. After about 5-10 minutes, when the wood is flaming brightly, latch the door (some longer flue installations may require door to be left unlatched for up to 15 minutes until the flue system is warm and producing strong draft. Since leaving the door open slightly can cause dangerously high temperatures, never leave the woodstove unattended while starting the fire.

When the flames from the kindling load just begin to subside, add several **small** pieces of firewood. Try to avoid smothering the fire with the new pieces. Placing the pieces on and behind the burning kindling can help prevent smothering. As your Jayline heater is a convection heater it requires approximately 45-60 minutes to preheat the steel firebox before it can effectively convect heat into the room. A well maintained, hot fire will reduce the preheat cycle.

REKINDLING A FIRE FROM CHARCOAL OR EMBERS

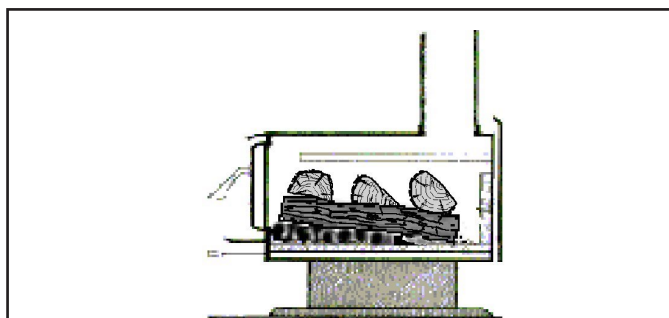

TO REKINDLE A FIRE FROM HOT COALS:
Rake the charcoal towards the front of the stove where the combustion air enters. Place small pieces of wood on and behind the coals. Open the air inlets fully and leave them open until the pieces of wood are well charred. This illustration shows the arrangement of pieces for an extended fire.

Embers found at the back of the firebox should be raked towards the front of the fire. If only a small amount of embers remain, you will have to start with kindling. If there is a good quantity of glowing embers to work with, place at least three, and preferably more than five pieces of small firewood on and behind the embers. Open the air inlets fully and close the door.

If everything is just right, instant ignition of the new load should be expected. Allow the fire to burn with bright turbulent flames until the wood is completely alight. This usually takes between 15 and 30 minutes, depending

on the size of the pieces and the moisture content of the wood. When the wood is burning well, reduce the air setting to produce the amount of heat and length of burn desired. Reducing the air control setting in two or three stages will result in less air pollution because the fire will not have to recover from the single, large reduction in air supply. The most important rule is **NEVER LET THE FIRE SMOULDER**. As long as there is solid wood in the firebox, there must be flames present or the unburned gases will escape, both reducing efficiency and increasing air pollution.

SOME OTHER USEFUL TIPS

Fuel load geometry: Small pieces of firewood arranged loosely in a crisscross pattern burn quickly because the combustion air can reach all the pieces at once. Larger pieces placed a little more compactly burn slower. Never add just one or two pieces of wood to a fire; three or more pieces are needed to form a sheltered pocket of glowing embers that reflect heat toward each other and sustain the fire.



A SMALL-STACKED FUEL LOAD
Good for short-duration fires

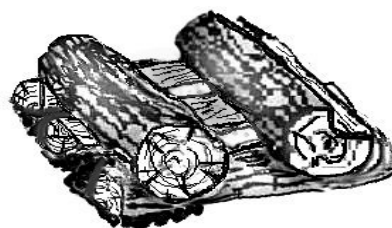

A LARGE-STACKED FUEL LOAD
Good for extended burning cycles

Small and Large Fuel Load Geometry

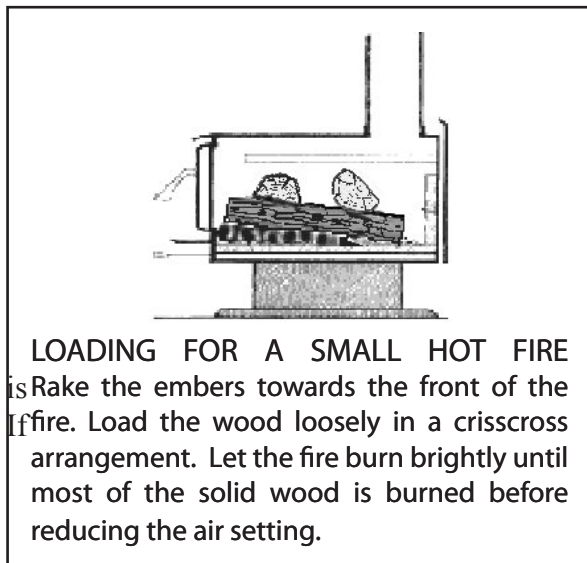

Fire in cycles: Don't expect perfectly steady heat output from your Jayline heater. Solid fuel heaters burn best in cycles. A cycle is the time between the ignition of a load from charcoal and the consumption of the load back to a coal bed. Each cycle should provide between four and eight hours of heating, depending on how much wood was used and how much heat is needed. Plan the firing cycles around your household routine. If someone home to operate the heater, build a small hot fire. If you must be away from the house during the day, build a long-burning fire.

The small, hot fire: A small, hot fire is a small amount of wood burned quickly. Use it when you

just want to take the chill off the house. The small hot fire technique eliminates the smouldering fires that are common when people don't need their heater running hot all the time, like in spring and autumn.

To build a small hot fire, rake the embers towards the front of the fire and place several small pieces on it. The bottom layer should be placed to ensure that combustion air can flow over the embers and along the length of the pieces of wood. The next layer should be stacked loosely in a crisscross arrangement. Open the air inlet to produce a hot, bright fire. After approximately 15–20 minutes the air supply can be reduced slightly as the fire progresses, but never enough to extinguish the flames. When only charcoal remains, the air supply can be reduced further to prevent cooling the ember bed.

The long-burning fire: To achieve a long burning fire, rake the embers towards the air inlets, as with the small hot fire, and use larger and more pieces of wood. Place the pieces in a similar pattern to the small hot fire, using more pieces and larger pieces (especially the top layer). **Always make certain that there is a gap between the pieces to ensure that the combustion air can reach all pieces.** Open the air inlets fully for between 15 to 30 minutes depending on load size and fuel moisture content. When the fire is burning fiercely (at least 15 minutes), reduce the air control in stages to the desired level. This allows you to turn down the air control and still maintain a clean-burning fire. **REMEMBER: NEVER LET THE FIRE SMOULDER.**

Preventing creosote build-up: Creosote is a tar-like substance that builds up when the organic compounds in smoke condense onto cooler flue surfaces. Left to build up over time, creosote will restrict the airflow of the flue and impair the performance of your heater. The production of smoke is at its highest when a fresh fuel load is added or when the air control is at its lowest position. The most effective way to control the creosote formation is to burn the heater so as to ensure as complete combustion as possible and at the same time promoting higher flue temperatures. Smoldering fires should always be avoided.

The amount of charcoal in the ash is often a good indicator of how well you are operating the heater. If there is no charcoal and only very fine ash, then you are doing an excellent job. If there is a lot of charcoal you may be turning the combustion air down too soon after refuelling, or not raking the charcoal to the combustion air inlet, or turning the combustion air down too low to support efficient combustion, or all of the above. *REMEMBER: THE HOTTER THE FIRE, THE LESS CREOSOTE FORMATION.*

When you have mastered the techniques for efficient wood burning, here is what you should see:

1. When wood burns it should be flaming until only charcoal remains. If there are no flames, something is wrong.
 2. Firebricks in the firebox should be tan in colour, never black.
 3. Steel parts in the firebox should be light to dark brown, never black and shiny.
 4. With seasoned wood, correct air settings and proper loading arrangement you should expect instant ignition of a new load of wood—the bottom pieces should be flaming by the time the door is closed.
1. The glass door should be clear. A discoloured glass indicates that the wood is too wet or the air control has not been left open long enough.
 2. The exhaust coming from the top of the flue system should be clear or white. A plume of blue or grey smoke indicates smouldering, inefficient combustion, air pollution and probably low operating temperatures.

Correctly installed and operated, Jayline solid fuel heaters do not spill smoke into the house. There are three main reasons why some woodstoves smoke:

Bad installation design: Incorrect flue installation, resulting in low flue temperatures and low draft, can make a wood heater more likely to spill smoke. For example, flue systems that run up the outside wall of the house and are not correctly insulated can rob the heat from the flue and produce very little draft. Each elbow in the flue pipe assembly slows down the flow of gases and causes a small restriction to flow. When a flue system includes more than one elbow, the restriction can be enough to cause spillage.

Extreme negative pressure in the house: Energy efficiency practices and new building code rules are making our houses more and more airtight. This makes the houses energy efficient, but also makes them more sensitive to negative pressure when air is exhausted from the house. Large, fan-forced exhaust ventilators, like down-draft-type kitchen stove exhausts, can cause extreme negative pressure in the house when they are operating. Because new houses are tightly sealed, there are few holes to allow replacement air to enter, and the house pressure becomes negative. This negative pressure works against flue system draft. In severe cases, the negative pressure in the house overcomes the flue system draft and the appliance begins to spill smoke, especially when a fire is started or when it dies down to coals. To prevent this extreme negative pressure, one option is to open a window to allow combustion air into the room.

Improper heater firing technique: When a solid fuel heater is starved for air it smoulders, producing a relatively cool, smoky fire. The temperatures throughout the system are low. During a smouldering fire, the flue system will not be receiving the hot gas it needs to produce strong draft. When the heater door is opened, smoke will spill into the room. A smouldering fire is the single most common reason for smoke spillage and totally unnecessary. By using the suggestions on proper firing technique earlier in this document, you will be able to avoid these smouldering fires.

PURCHASING THE FIREWOOD

The quality of the firewood you burn can have a dramatic effect on the efficiency and operation of the heater. The main factors that affect the burning characteristics of firewood are moisture content, tree species and piece size. The moisture content of the wood affects the rate at which it burns and the efficiency of combustion. When trees are cut, the wood moisture content ranges between 35 and 60 percent by weight*. If you attempt to burn wood this wet it will be hard to ignite, slow to burn and will hiss and sizzle in the firebox. So much energy will be consumed in boiling off the excess water that the efficiency of combustion and the heat to your home will be low, condensation and corrosion may be occurring in the flue and smoke may be causing problems to your neighbours. Properly seasoned wood ignites readily and burns efficiently.

Firewood should be cut and split in the early spring and stacked under cover, with good ventilation, to be ready for burning when required.

Look for checks or cracks in the end grain as a sign of dry wood. The stacks of firewood should be in an open area so that air can circulate through them. During the summer, as warm breezes flow through the stacks, carrying away the evaporating water, the moisture content of the wood will fall to around 20 per cent. At this moisture content the wood is ready for burning.

Although the energy content of dry wood per kilogram is almost the same regardless of species, softwoods and hardwoods burn differently because of differences in density. Softwoods, such as pine, are less dense than hardwoods like gums, Manuka or Black Wattle. A denser wood will produce a longer-lasting coal bed, while a less dense wood will bring a fire to an optimum burning temperature more quickly.

The size of the firewood pieces affects the rate of combustion. Larger pieces ignite and release their energy more slowly than small pieces. Smaller pieces are better for short, hot fires and larger pieces are preferable for extended firing cycles. In general, commercial firewood dealers supply firewood in thicker pieces than modern wood-burning heaters can handle. It is often necessary to split some of the wood again before using it. The thickest piece size for high-efficiency heaters should not exceed about 150 mm (6 in.) across the largest dimension and a range of smaller pieces will be needed for effective stoking. Maximum log length varies according to model.

***CANTERBURY RESIDENTS PLEASE NOTE: WOOD WITH A MOISTURE CONTENT OF 25% OR LESS IS THE ONLY APPROVED FUEL FOR USE IN THE CANTERBURY CLEAN AIR ZONE.**

BURNING COAL

Due to their construction, the burning of coal in Jayline solid fuel heaters is prohibited. Please also refer to 'Exclusions' in the Warranty Page 15.

Jayline Solid Fuel Heater Maintenance

To keep your heater burning clean and efficient it is important that you carry out regular maintenance. General maintenance checks should include the following:-

ASH REMOVAL

Due to the high efficiency of your Jayline heater, ash removal should only be necessary every few weeks. Ashes can be removed easily through the fire door when the fire is at its lowest, such as first thing in the morning, or when it is completely out and cold. Ash should be placed in a non combustible container with a tightly fitting lid and moved outdoors immediately to a location clear of combustible materials. Jayline heaters work best when a small amount of ash (approximately 20mm deep) is left in the firebox after cleaning. This insulates the bottom and prevents the base of the stove overheating and burning out. In fact, maintaining a minimal ash bed helps with re-lighting the fire.

SURFACES

Jayline solid fuel heaters have vitreous enamel surfaces that just need wiping clean.

FIREBOX

Check the firebricks, top baffle and interior surfaces. These parts are subjected to considerably high temperatures and stress and some parts will eventually need replacing.

DOORS

Check all gaskets used for wear and replace if necessary. Adjust door fitting if required.

LUBRICATION

All moving parts should be lubricated with graphite grease every couple of months.

GLASS CLEANING

On occasion it will be necessary to clean the carbon deposits and fly ash off of the glass. If the carbon and fly ash are allowed to remain on the glass for an extended period of time it could eventually cause the glass to become etched and cloudy. Any creosote that might develop on the glass will burn off during the next “**hot**” fire.

Follow this cleaning procedure:

1. Glass needs to be *completely cool*.
2. Only use a cleaner that is specifically designed for this purpose. The use of abrasives will damage the glass and ultimately leave the glass frosted.
3. Rinse and dry glass completely before burning the stove.

Caution! Always operate the door slowly and carefully to avoid cracking or breaking the glass. Never use the door to push wood into the firebox. The glass itself is not covered by any warranty. If the glass becomes cracked or broken follow the replacement procedure below. *Never operate the stove with a cracked or broken glass panel.*

CHIMNEY CLEANING AND CHECKING FLUES

For all wood heaters, flue cleaning must be done regularly to avoid serious flue fires. Frequently used heaters should be cleaned at least once a year (some sooner). The cleaning rate, however, depends on the burning habits of the individual operating the wood heater. For example, it is possible to clog a flue in just a few weeks if smouldering fires are burnt and the flue is run cold.

It is recommended that flue sweeping be done by a professional chimney sweep. Chimney sweeping is a specialist task and competent professional sweeps are available throughout the country. When the flue is cleaned it is recommended that other parts, such as baffles, are checked.

Flue systems should be checked at least once or twice a heating season. Flue systems may require checking more often if the fuel or operation of the appliance is incorrect. When a flue system becomes excessively blocked or requires frequent cleaning, advice should be sought to investigate the installation and the operation of the heater. Flue pipes can deteriorate very quickly with incorrect firing.

Warnings

Below is a list of warnings to ensure efficient and safe operation of your Jayline heater:

- **WARNING: DO NOT USE FLAMMABLE LIQUIDS OR AEROSOLS TO START OR REKINDLE THE FIRE.**
- **WARNING: DO NOT USE FLAMMABLE LIQUIDS OR AEROSOLS IN THE VICINITY OF THIS APPLIANCE WHEN IT IS OPERATING.**
- **WARNING: DO NOT STORE FUEL WITHIN HEATER INSTALLATION CLEARANCES.**
- **WARNING: OPEN AIR CONTROL BEFORE OPENING FIRING DOOR.**
- CAUTION: THIS APPLIANCE SHOULD NOT BE OPERATED WITH A CRACKED GLASS.
- CAUTION: THIS APPLIANCE SHOULD BE MAINTAINED AND OPERATED AT ALL TIMES IN ACCORDANCE WITH THESE INSTRUCTIONS.
- CAUTION: THE USE OF SOME TYPES OF PRESERVATIVE-TREATED WOOD AS A FUEL CAN BE HAZARDOUS.

RETAIL LINKS WARRANTY

THIS IS AN IMPORTANT DOCUMENT - KEEP IT IN A SAFE PLACE

CONGRATULATIONS!

We at Retail Links appreciate your decision to invest in our product. Your heater will become an integral part of your lifestyle, heating your home during the colder months and at the same time maintaining its appearance as a quality appliance. We want you to get the best possible performance from your fire and for this reason ask that you read this booklet carefully to take full advantage of your warranty.

In particular we urge you to have your heater and flue inspected annually and the flue swept if necessary. At the same time any other minor potential problems can be detected and corrected before they turn into major ones.

We think this is a small price to pay to ensure your heater is kept in peak condition. There is no doubt in our minds that you will extend the life of your heater.

We select only certain companies to act as our Retail Links dealers. They must have high standards, be members of the Home Heating Association and are able to provide a total service both pre and post sale to you the customer. We have every confidence that our dealers will be able to answer your questions or fix any problem that may occur. If you have any further queries, please contact us at:

RETAIL LINKS

P O BOX 9056

ANNESBROOK, NELSON

NEW ZEALAND

FAX: 03 547 0770

EMAIL: info@jayline.co.nz

Thanks again for choosing a Jayline solid fuel heater. We wish you many warm winters to come!

RETAIL LINKS SOLID FUEL HEATER WARRANTY

10 YEARS (conditional)

Standard Warranty

This heater is warranted for ten years*, with the exception of the following: - door seal, glass, glass seal, firebricks, secondary air systems, and removable baffle which will have a twelve month warranty (parts only), provided it has been installed by a Home Heating Association registered installer, or an installer recognised by Retail Links.

Conditions

The heater must be installed in accordance with the manufacturers' instructions and all relevant standards, regulations and by-laws. The company is not liable for any consequential damage by a failure or defect covered by this warranty. All claims against this warranty must be directed first to the retailer of the store. Any repairs undertaken without the written authority of Retail Links will invalidate this warranty.

If a Water Booster is fitted (Rural models only), it must be a **Retail Links** Water Booster in order to be warranted.

The warranty is only valid to the initial purchaser of the product.

Exclusions

This warranty does not cover damage caused by:

- ◆ Mishandling, misuse, abuse, alteration.
- ◆ Normal wear and tear.
- ◆ Work done by others such as installers, plumbers or chimney sweeps.
- ◆ The burning of coal, particle board or the like, salt laden driftwood or any chemically treated wood or fuel of any kind.
- ◆ Other products such as flues or replacement.

The warranty does not cover delivery of the defective part to the dealer or its reinstallation following repair or replacement.

The manufacturer is not responsible for site conditions such as draughts, cleaning and servicing.

Procedure

If a defect occurs, contact your dealer and the part will be repaired or replaced at our option.

Transferability

This warranty is transferable in the following circumstance:

Removal of your heater to a new site as long as you use a registered installer.

It is recommended you have your dealer inspect your heater annually during the warranty period.

This warranty is in addition to your rights under the Sale of Goods Act and the Fair Trading Act.

RETAIL LINKS reserves the right to change specifications or design of its product without prior notice.